

# REQUEST FOR PROPOSAL

“THE SOUTHWEST TELEHEALTH ACCESS  
GRID”

University of New Mexico Health Sciences  
Center and Hospitals

RURAL HEALTHCARE PILOT PROJECT  
FUNDING YEAR 2009

SWTAG RFP 14

NETWORK INFRASTRUCTURE  
PROCUREMENT

University of New Mexico Purchasing Office  
1700 Lomas Blvd NE, Suite 2600  
Albuquerque, NM 87131  
Attn: Tom Weeks

# SWTAG RFP 14

## Table of Contents

	<u>Page</u>
<b>i.0 General Information</b>	<b>3</b>
<b>1.0 Administrative and Procedural Information</b>	<b>4</b>
<b>2.0 Proposal Evaluation</b>	<b>6</b>
<b>2.1 Proposal and Contract Terms</b>	<b>6</b>
<b>2.2 Design Compatibility</b>	<b>7</b>
<b>2.3 Implementation Timeframe</b>	<b>7</b>
<b>2.4 Provider / Vendor Qualifications</b>	<b>8</b>
<b>2.5 Cost</b>	<b>8</b>
<b>2.6 Proposal Guidelines</b>	<b>9</b>
<b>2.7 Evaluation and Decision</b>	<b>10</b>
<b>3.0 Site, Routing and Technical Information</b>	<b>11</b>
<b>3.1 Overview</b>	<b>11</b>
<b>3.2 Project Components</b>	<b>11</b>
<b>3.3 General Specifications for All UNMHSC and UNMH Sites</b>	<b>11</b>
<b>3.4 Dedicated Fiber Connection from the Women’s Faculty and Midwife Clinic         to the Physical Therapy Rehabilitation Clinic</b>	<b>14</b>
<b>3.5 Fiber Connections from the UNM Children’s Psychiatric Hospital to the Health         Sciences and Services Building</b>	<b>15</b>
<b>3.6 Fiber Connection from Novitski Hall Zone Hub to the University Psychiatric         Hospital</b>	<b>17</b>
<b>3.7 Fiber Connection from UNM Cancer Center to the Physical Therapy Rehabilitation         Clinic</b>	<b>18</b>
<b>3.8 Fiber Connection from UNM Cancer Center to the Health Sciences and Services         Building Zone-Hub via Medical Arts</b>	<b>19</b>
<b>3.9 Fiber Connection from the Physical Therapy Rehabilitation Clinic to UNM Hospital         Operations for Patients and Employees</b>	<b>21</b>
<b>3.10 Fiber Connection from the Sleep Disorders Center to the Physical Therapy         Rehabilitation Clinic</b>	<b>23</b>
<b>3.11. Fiber Connection from UNM Hospital to Health Sciences and Services Building         Zone-Hub (HSSBZH)</b>	<b>24</b>
<b>3.12 Upgrade for Internet Edge in HSSB Zone Hub and Novitski Zone Hub</b>	<b>23</b>
<b>3.13. Upgrade for Network Security in HSSB Zone Hub and Novitski Zone Hub</b>	<b>26</b>
<b>3.14 Upgraded HSC Intrusion Detection System</b>	<b>26</b>
 <b>Appendices</b>	
<b>Appendix A: Site Connectivity Drawings</b>	<b>27</b>
<b>Appendix B: Detailed Site Specifications</b>	<b>28</b>
<b>Appendix C: UNM IT / Telecommunications Specifications and Design         Guidelines</b>	<b>42</b>

## **i. General Information**

i.1. Introduction. The Southwest Telehealth Access Grid (SWTAG) Project is one of the Federal Communication Commission's (FCC) Rural Healthcare Pilot Programs (RHCPP). It is an integrated interstate network of networks built upon the extensive experience of key participants in rural telemedicine and rural healthcare in New Mexico, Arizona and the Southwest Indian Health Service (IHS) Telehealth Consortium and associated Tribes. This Grid creates the platform to more effectively share, distribute and coordinate telemedicine clinical services, educational and training programs among the healthcare provider organizations across the region, along with their associated human resources, thus more easily and effectively filling the gaps in meeting the health care needs of the rural communities throughout the network. Through Internet2 (I2) and the National Lambda Rail (NLR), this regional TAG network of networks, which is greatly facilitated and enhanced by the current USF Rural Healthcare Pilot Program, will enable our participating hospitals, clinics, and educational institutions to partner with peers throughout the United States to improve healthcare delivery and education via telemedicine.

The University of New Mexico is an accredited post-secondary educational and research institution which includes a Health Sciences Center (UNMHSC) with Schools of Medicine, Nursing and Pharmacy which provide distance education to many rural clinics and educational entities around the State of New Mexico. UNMHSC also has clinics distributed in the city of Albuquerque which provide clinical services to rural communities via telemedicine. The University of New Mexico Hospitals (UNMH) are a group of hospitals and clinics located throughout the city of Albuquerque which support rural health care entities in the State of New Mexico via telemedicine. As the University's telehealth systems are implemented and mature, the need for reliable, secure and robust broadband telecommunications connections becomes critical.

i.2. The SWTAG, UNMHSC and UNMH will construct an interconnected broadband network that links providers in the rural communities. Funding provided by the Federal Communications Commission (FCC) under the Commission's order 07-198 ('Rural Healthcare Support Mechanism') of 19 November 2007, as well as matching and participatory funds as defined in the Order and provided by the participants and their member sites and organizations will be utilized to construct this network.

i.3. Overview. The UNMHSC and UNMH FY09 project is designed to augment and enhance the existing wide-area networks of its member sites around the city of Albuquerque to enhance its ability to provide telehealth services over broadband to rural New Mexico. UNMHSC and UNMH are soliciting bids from vendors, suppliers and service providers to provide the connectivity (carrier-based broadband and dedicated fiber optic cable installations) and any required edge network electronics and devices.

i.4. Bidders are asked to provide proposals based on the accompanying site, routing, and technical information. Although consolidated bids for connectivity, hardware, and services will be considered, vendors are encouraged to submit bids for technological, logical, or geographical segments of the project. Thus, UNMHSC and UNMH will entertain three types of bids under this RFP.

i.5. Consolidated – One inclusive price to provide connectivity, equipment and carrier services for any or all of the sites, areas, or regions according the specifications set forth in this RFP.

i.6. Connectivity – Price to provide connectivity and carrier services for any or all of the sites, area, or regions defined in this RFP.

i.7. Hardware – Price to provide hardware (logical network components, as defined herein) for any or all of the sites, area, or regions defined in this RFP.

i.8. The RFP process will allow the UNMHSC and UNMH to receive the competitive offers for network development from independent telephone companies, local exchange carriers, cable operators, hardware distributors and manufacturers, cabling and construction contractors, and others. These competitive offers will be judged by UNMHSC and UNMH according to the criteria set forth within Section 2.0, and its subcomponents, of this document.

## 1.0 Administrative and Procedural Information

1.1. The Rural Health Care Pilot Program (RHCPP) of the Universal Service Fund, which is administered by the Universal Service Administrative Company (USAC), is a support program authorized by Congress and designed by the Federal Communications Commission (FCC) to encourage the development of rural broadband networks to provide advanced healthcare telecommunications capabilities and services to rural health care providers (HCPs).

1.2. Notice: This project is subject to the USAC procurement rules. Vendors must meet all USAC requirements. The SWTAG will submit a USAC Form 465 to USAC who will review the documentation and will post the RFP on the USAC website. More information on bidding and posting rules can be found at <http://www.lifelinesupport.org/rhc-pilot-program/vendors>.

1.3. The following considerations apply to the proposal submission / review process:

1.3.1. Bidders may view Rural Health Care Pilot Participants FCC Form 465 and Project Scope Document postings at <http://www.usac.org/rhc-pilot-program/tools/search-postings-2009.aspx> **This site shows the official RFP posting date and the allowable contract date.**

1.3.2. The SWTAG, in partnership with the University of New Mexico Purchasing Department, has established a website for the convenience of bidders. All RFP materials and associated documents will be posted on the UNM e-Procurement site, LoboSource. Note: While registration is suggested (via the Supplier Registration link), it is not required and SWTAG bidders may access information directly through the [Current Bid Opportunities](#) link. (Please note: LoboSource is not compatible with Internet Explorer 7 and above. You must use IE 6 or Mozilla Firefox.)

**The LoboSource (SWTAG) bidder site may be reached at**  
<http://www.unm.edu/~purch/lobosource.html>

1.3.3. Questions from Bidders. It is the responsibility of the bidder to inquire about any condition of this RFP that is not understood. Queries from bidders will be accepted via e-mail only and no later than 10 days prior to bid closing date, as described herein. Questions to individual UNMHSC, UNMH or SWTAG staff members via telephone/telefacsimile, e-mail or postal mail, will not be entertained.

All communication and inquiries, unless otherwise noted, must be directed to Denise Dion at the University of New Mexico Center for Telehealth. Bidders wishing to submit questions or request technical clarifications concerning this UNMHSC and UNMH RFP should send e-mail inquiries to Denise Dion at [dmdion@salud.unm.edu](mailto:dmdion@salud.unm.edu) with a copy to Tom Weeks at UNM Purchasing ([tomweeks@unm.edu](mailto:tomweeks@unm.edu))

Responses to all questions submitted will receive written responses as soon as possible and will constitute official communications from the UNMHSC and UNMH project. Note: any and all question submittals and requests for clarification must be provided in writing and submitted no later than 10 days prior to bid closing date. Responses to inquiries, if they change or clarify the RFP in a substantial manner, will be posted/distributed as a written addendum to this RFP. Any communications with SWTAG, UNMHSC or UNMH staff members other than as noted above

should not be considered authoritative, are not binding on SWTAG, UNMHSC or UNMH ,and may be disavowed without notice or explanation.

1.3.4. In the event it becomes necessary for UNMHSC and UNMH to amend, add to or delete any part of this RFP, the amendment will be posted on the USAC web site, as required by the Order and by the USAC-mandated bidding procedures, and will additionally be posted on the SWTAG bidder site.

1.3.5. Bid proposals must be received at the University Purchasing office no later than 28 calendar days from the date of posting of this RFP on the USAC website. This receipt deadline requirement is a mandatory requirement and is not subject to waiver by SWTAG, UNMHSC or UNMH. Accordingly, no bid proposals will be accepted after the date and time specified. A late bid proposal will be returned unopened to the bidder.

1.3.6. No bid proposal will be accepted by telephone, electronic mail or facsimile. The proposal receipt deadline is for actual receipt in the UNMHSC and UNMH delivery location shown in Section 1.3.7. Delivery, whether via postal mail or other service, must be arranged to assure arrival before the deadline set forth above.

1.3.7. Two original hard copy bid proposals must be mailed or otherwise physically delivered to each of the following addresses:

University of New Mexico Purchasing Office  
UNMHSC and UNMH Project  
1700 Lomas NE, Suite 2600  
Albuquerque, NM 87131  
Attn: Tom Weeks

UNM Center for Telehealth  
Southwest Telehealth Access Grid Project  
1005 Columbia NE  
Albuquerque, NM 87106  
Attn: Melissa Crews

In addition, two copies of the proposal on CD must be delivered to the University of New Mexico Purchasing Office, 1700 Lomas NE, Suite 2600, Albuquerque, NM 87131 (Attn: Tom Weeks).

It is strongly suggested that certified delivery services be used to verify the receipt of bids by University Purchasing office.

1.3.8. The bid proposals and the evaluation documents created by UNMHSC and UNMH will remain confidential until UNMHSC and UNMH has evaluated all of the compliant bid proposals submitted in response to this RFP and the selection process is complete. Once the evaluation and selection process is complete, all information, except that classified as confidential, will become public information will be available for inspection on the SWTAG web site.

1.3.9. Award information will be posted electronically on the SWTAG web site, LoboSource through the [Awarded Bid Information](#) link.

#### 1.4. Bid Proposal General Requirements

1.4.1. Failure to comply with or supply any and all information requested to accompany bid proposals may be cause for rejection of the proposal as non-compliant.

1.4.2. Bidder assumes all costs of preparation of the bid. The University of New Mexico, SWTAG, UNMHSC, and UNMH and any of their employees or officers shall not be held liable for any

expenses incurred by any bidder responding to this RFP for expenses to prepare, deliver the proposal, or to attend any mandatory pre-bid meeting or oral presentations.

1.4.3. All bid proposals must be valid for a period of 90 days from the date of submission.

1.4.4. By submitting a bid proposal the vendor agrees to the terms and conditions contained within this RFP.

1.4.5. Multiple Awards. The University reserves the right to make multiple awards to a primary and secondary source, or to otherwise split the award of the items, projects, and/or sections of this proposal.

## **2.0 Proposal Evaluation**

### **2.1. Proposal and Contract Terms (10 possible points)**

2.1.1. The primary objective of this RFP, and any subsequent contract, is to obtain the most feasible and cost-effective installation with the required standards for product and service delivery. Bidder proposals will be evaluated for compliance with all instructions, specifications, and the terms and conditions.

2.1.2. Offers will be evaluated and scored based upon how well the bidder describes/responds to the following:

2.1.3. Vendor's response to the RFP demonstrates a clear and complete understanding of the goals of the overall project.

2.1.4. Bidder's proposition is for providing the consolidated project needs – i.e., proposals that combine connectivity, hardware, and services.

2.1.5. The above notwithstanding, vendors may bid for connectivity, network edge hardware or site specific bids based on geographic area of coverage.

2.1.6. Connectivity services – Bids are provided for 1-year, 2-year, 3-year and 5-year duration (except where noted in the detail site listing).

2.1.7. Hardware service and maintenance – Bids are provided for 1-year, 2-year, 3-year and 5-year duration.

2.1.8. Service Level Agreement and/or Performance guarantees are provided, including uptime and response time guarantees.

2.1.9. Proposed system testing and acceptance provisions will be required on all bid proposals. UNMHSC and UNMH reserve the right to work in concert with vendors to develop appropriate testing and acceptance criteria for specific installations or configurations, to be defined and accepted by both parties prior to contract initiation.

2.1.10. Any contract resulting from this RFP will contain specific deliverable items acceptance provisions.

2.1.11. Bid proposals will contain acknowledgement of, and provisions for providing, USAC invoicing requirements and formats. Bidder will conform to invoicing procedures and processes as promulgated by USAC.

2.1.12. Bidder agrees to provide a project manager or other individual who will be the primary contact for all dealing with UNMHSC and UNMH.

2.1.13. The successful Contractor will be required to provide full documentation upon completion.

## **2.2. Design Compatibility (10 possible points)**

2.2.1. Offers will be evaluated and scored based upon how well the bidder describes/responds to the following:

### **2.2.2. Connectivity Services**

2.2.2.1. Bidder's proposal accounts for existing network design within the member site network(s) to which its bid applies, and does not require re-grooming or reconfiguration of circuits or transports not directly impacted by the project. (This requirement does not include the decommissioning of existing circuits being replaced by new UNMHSC- and UNMH-specified circuits.)

2.2.2.2. Bidders for any optical circuits or raceways must comply with design guidelines in Appendix C.

### **2.2.3. Hardware Components**

2.2.3.1. Bidder's proposal for hardware meets the stated requirements of the RFP in all respects without substitution or alteration of required functionality.

2.2.3.2. Bidder's proposal accounts for existing hardware components and network logical and physical topology, and does not impose restrictions or reconfiguration requirements to accommodate specifications of proposed equipment that do not meet RFP requirements. (This requirement does not include the reconfiguration or decommissioning of existing equipment being replaced by new UNMHSC- and UNMH-specified devices.)

2.2.3.2.a Compatibility with current HSC Network management applications and routing protocols is critical. In particular, all network electronics needs to be able to be managed by CiscoWorks Resource Manager Essentials version 4.3.x via SNMP v3 & SSH and all layer 3 switches and routers need to support OSPF. (This section will be explicitly waived in one or more projects.)

2.2.3.3. Bidder's proposal includes maintenance and support contract options.

2.2.3.4. Bidder's proposal includes only those installation and configuration services specifically requested in the RFP.

## **2.3. Implementation Timeframe (20 possible points)**

2.3.1. Offers will be evaluated and scored based upon how well the bidder describes/responds to the following:

2.3.2. Implementation timeline must begin no later than 30 days from the date of award notification.

2.3.3. Bid proposals must identify each (any or all) specific portion of the project the offeror proposes to perform, and include a project plan and timeline detailing milestones and overall

schedule for each. Critical path items and potential delay circumstances must be clearly identified.

## **2.4. Provider / Vendor Qualifications (20 possible points)**

2.4.1. Offers will be evaluated and scored based upon how well the bidder describes/responds to the following:

2.4.2. Bidder possesses the ability to provide proposed services or products in the manner and within the timeline(s) specified in the RFP, as determined by UNMHSC and UNMH, based on:

2.4.2.1. Describe the prior experience and qualifications related to accomplishing the work as requested. Bidder must provide a current Service Provider Identification Number (SPIN) in their proposal.

2.4.2.2. References: provide a list of references that identifies services provided on contractors for similar work. Include telephone numbers and mailing addresses of individuals who can attest to the Bidder's experience and qualifications of the services requested.

2.4.2.3. Reputation in the industry. Provide background regarding the Bidder, including: length of time in business, other activities performed by the Bidder, and number of individuals on staff (including owners, partners, and employees).

2.4.2.4. Contractor's history of reliability and customer service based on past performance in the experience of one or more of the UNMHSC and UNMH member sites; and

2.4.2.5. Objective qualifications of key staff and proposed project personnel. Describe the experience and qualifications for the specific individuals who will provide the work.

## **2.5. Cost (30 possible points)**

2.5.1. Offers will be evaluated and scored based upon how well the bidder describes/responds to the following:

2.5.2. UNMHSC and UNMH will select the most cost effective bid or bids presented, whether that is a consolidated bid for all sites in the UNMHSC and UNMH project, as defined herein, all sites within a member's region, or site-by-site bids for connectivity or hardware.

2.5.3. All costs may not qualify for RHCPP funding, so it is critical that accurate, detailed cost information be provided for all portions of the bid proposal. Please indicate on your proposal that this is understood.

2.5.4. Bid proposals must identify all costs associated with the proposed solution, including design, installation, configuration, maintenance, and monthly recurring costs.

Specifically, for connectivity proposals include costs for:

2.5.4.1. Implementation fees, including one-time connection or provisioning charges, hardware costs.

2.5.4.2. Monthly recurring charges amortized over the period of the proposed contract, for transmission at the proposed bandwidth, port charges, transport charges, taxes, fees, and assessments.

2.5.4.3. Contract termination provisions, including specific penalties, if any, for early termination by UNMHSC and UNMH.

Specifically, for hardware and fiber installation proposals include costs for:

2.5.4.4. Purchase price for each unit. Bundled pricing may be cited, but individual components must be identified and detailed pricing provided.

2.5.4.5. Shipping costs for each unit or shipment.

2.5.4.6. Design, engineering, configuration and installation charges.

2.5.4.7. Taxes, permits, fees, licenses.

2.5.4.8. Maintenance and/or support charges for the proposed contract period.

## **2.6. Proposal Guidelines (10 possible points)**

2.6.1. Bidders are to organize proposals in the order stated in this section. In responding to this RFP, Bidders are encouraged to provide additional information if Bidder believes that information to be relevant. Responses should provide the details required and not solely a statement of acknowledgment. The submission of proposals must be organized to include, but not be limited to the following information:

2.6.1.1. Name, address, e-mail address, telephone numbers, and facsimile number of the Bidder.

2.6.1.2. Name, title, e-mail address, and telephone number of the primary contact of the Bidder.

2.6.1.3. A signature of the Bidder or of an officer/employee who certifies that he/she has the authority to make the bid.

2.6.1.4. A statement of the Bidder, if awarded the contract, will comply with the contract Terms and Conditions as set forth in this RFP. USAC procedures and processes must be met. Please provide a statement containing acknowledgement of, and provisions for providing, USAC invoicing requirements and formats.

2.6.1.5. A detailed description of the work proposed in response to this RFP. The submission must include, but is not limited to, addressing all requirements and each question contained within Section 2.1, Section 2.2, and Section 3.0 and their subparagraphs.

2.6.1.6. The proposed implementation timeline and project plan, per Section 2.3 and its subparagraphs.

2.6.1.7. A detailed cost proposal for providing the services requested, per Section 2.5 and its subparagraphs.

2.6.1.8. Provide evidence of the vendor's prior experience and qualifications related to accomplishing the requested work. Address each item in Section 2.4 and its subparagraphs.

2.6.2. Provide a statement with the dates for which this offer is valid.

## **2.7. Evaluation and Decision**

2.7.1. The selection will be based on all factors indicated in this RFP, and may not go to the lowest bidder if cost is outweighed by a combination of other features in the winning vendor's bid. Appendix D: SWTAG FCC Pilot Program Vendor Evaluation – UNMHSC and UNMH, on page xx, indicates the evaluation criteria and scoring.

2.7.2. UNMHSC and UNMH reserve the right to select bid proposals which, in the sole judgment of UNMHSC and UNMH, most nearly conform to the specifications set forth herein, will best serve the needs of UNMHSC and UNMH and its member sites and participants, and provide the most cost-effective means for producing those results.

2.7.3. UNMHSC and UNMH reserve the right to waive any and all issues of form or presentation in considering bid presentations for acceptance or rejection, if, in the sole opinion of UNMHSC and UNMH, such waiver is in the best interests of the project.

2.7.4. UNMHSC and UNMH are not responsible for any costs incurred by a vendor related to the preparation or delivery of the bid proposal, or any other activities carried out by the vendor, as it relates to this RFP.

2.7.5. UNMHSC and UNMH are not obligated to accept any proposal received in response to this RFP. In particular, UNMHSC and UNMH may accept received proposals in whole or in part, or may reject all proposals received.

2.7.6. Changes in applicable laws and rules may affect the award process or any resulting contracts. Vendors are responsible for ascertaining pertinent legal requirements and restrictions. Vendors are encouraged to visit the official Federal websites pertaining to the Pilot Project, at <http://www.lifelinesupport.org/rhc-pilot-program/> and <http://www.fcc.gov/cgb/rural/rhcp.html>.

2.7.7. The selection decisions made by UNMHSC and UNMH, and reported to SWTAG and USAC under this RFP are final, and appeals or re-submissions will not be considered.

## 3.0 Site, Routing, and Technical Information

3.1. Overview. The UNMHSC and UNMH project consists of the addition and enhancement of broadband connectivity, fiber optic cable installation, and concomitant site-based network routing hardware at twenty one (21) sites in New Mexico in support of its participation in the SWTAG and that project's selection as a participant on the FCC Rural Healthcare Pilot Program.

3.2. Project Components. The requirements for this RFP are grouped by scope subcomponents to enable vendors to most effectively evaluate the site(s) for which to submit proposal(s).

- Section 3.4: Dedicated Fiber Connection from the Women's Faculty and Midwife Clinic to the Physical Therapy Rehabilitation Clinic,
- Section 3.5: Fiber Connections from the UNM Children's Psychiatric Hospital to the Health Sciences and Services Building Zone-Hub,
- Section 3.6: Fiber Connection from the Novitski Hall Zone-Hub to the University Psychiatric Hospital,
- Section 3.7: Fiber Connection from UNM Cancer Center (UNMCC) to the Physical Therapy Rehabilitation Clinic,
- Section 3.8: Fiber Connection from UNM Cancer Center to the Health Sciences and Services Building Zone-Hub (HSSBZH) via Medical Arts ,
- Section 3.9: Fiber Connection from the Physical Therapy Rehabilitation Clinic to UNM Hospital Operations for Patients and Employees,
- Section 3.10: Fiber Connection from the Sleep Disorders Center to the Physical Therapy Rehabilitation Clinic,
- Section 3.11: Fiber Connection from UNM Hospital to Health Sciences and Services Building Zone-Hub (HSSBZH),
- Section 3.12: Upgrade for Internet Edge in HSSB Zone Hub and Novitski Zone Hub,
- Section 3.13. Upgrade for Network Security in HSSB Zone Hub and Novitski Zone Hub, and
- Section 3.14 Upgrade for HSC Intrusion Detection System in HSSB Zone Hub and Novitski Zone Hub.

### 3.3. General Specifications for All University of New Mexico Health Sciences Center and Hospital Sites

3.3.1. All broadband links specified are to provide transport between each indicated originating site and termination site. See Appendix A, page 22 for the Site Connectivity diagram.

The UNMHSC and UNMH wide-area network system is currently maintained by

University of New Mexico Hospitals  
2211 Lomas Blvd. NE  
Albuquerque, NM 87106-2745

3.3.2. The requirement to connect to the existing UNMHSC and UNMH wide-area network system notwithstanding, bidders are encouraged to propose specific designs for providing the backhaul services and connectivity needed to accomplish that goal.

#### 3.3.3. Connectivity Requirements – Broadband Links

3.3.3.1. All circuits are to be fully provisioned from end-point to core location. Physical facility installation to the demarcation point at each site affected must be included in the bid.

3.3.3.2. Transport: To be determined by vendor, but must be transparent to layer-2 and higher protocols, including UNMHSC and UNMH wide-area network. Use of techniques like 802.1Q Tunneling to accomplish this is acceptable.

3.3.3.3. Bandwidth: Specified within each scope subcomponent section (Sections 3.4 through 3.12), as well as in Appendix B: Detailed Site Specifications.

3.3.3.4. Latency: < 60ms; (between site and core routers as identified within the scope subcomponent sections, Sections 3.4 through 3.12).

3.3.3.5. Stability (video): jitter: good 0 – 20 ms, acceptable 20 – 50ms; packet loss good 0 – 0.5%, acceptable 0.5 – 1.5%.

3.3.3.6. Site connectivity physical circuit redundancy should be proposed where the site's location and circumstances provide the capability of effectively providing redundant entry points to the facility, and the appropriate network hardware needed to manage the redundant circuits.

3.3.3.7. Site connectivity backhaul redundancy and resiliency should be proposed when possible, to provide separate physical and logical paths for redundant circuits. Resiliency for backhaul circuit transport is required, with provisioning to take into account that need.

3.3.3.8. Physical facilities and provisioning to the demarcation point of each site must be included in the proposal, where needed.

#### 3.3.4. Connectivity Requirements – Dedicated Fiber Links

3.3.4.1. Inter-building dedicated external fiber optic cable installations are solicited for the locations as specified in Appendix B: Detailed Site Specifications.

3.3.4.2. End-to-end fiber optic cable installation between the facility-designated telecommunications demarcation point in both sites of each site pair is required. Routing and installation particulars are to be determined by the bidder in accordance with the specifications below, and must be described in the bid proposal.

3.3.4.3. Dedicated fiber installation bids are to include all labor and materials needed for the installation of the specified fiber connectivity, including site survey, engineering, fiber installation, termination, and others specified in the site detail.

3.3.4.4. Documentation, including final site survey, engineering drawings, fiber installation specifications and 'as built' drawings, is to be provided in a timely fashion upon the acceptance on an installation bid by UNMHSC and UNMH.

3.3.4.5. The vendor will obtain permits from departments and/or agencies of cities, state, county, and federal government, railroads, or other entities which provide for the placement of facilities within their respective rights of way.

3.3.4.6. The vendor will provide easements for construction on private lands, as needed. Any and all easements must be approved by UNMHSC and UNMH prior to implementation. It is preferred that all easements be one time, advance payments with no recurring charges. Existing UNM underground facilities should be used where available, practical and cost effective. For certain fiber links the use of 3<sup>rd</sup> party conduits and/or duct systems is allowed if rights can be obtained, this is specified in the project description.

3.3.4.7. All external fiber installation must comply with fiber and raceway design guidelines specified in Appendix C. In addition outdoor fiber will be interlocked armor cable, exceptions must be approved by George Thorning of UNM IT or his designee.

3.3.4.8. All fiber installation will be installed and tested in accordance with industry-standard practices, including but not limited to the standards promulgated in the National Electrical Safety Code (IEEE C-2), NFPA 70, TIA-590-A, and TIA-758-A, all as amended. Installation will meet all local building and electrical codes.

3.3.4.9. One hundred percent (100%) of all fiber optic media must be tested in accordance with TIA/EIA-568-B.1, TIA/EIA-568-B.3, and TIA-526-7 (single mode). OTDR instrument must be calibrated to show anomalies of .02dB minimum, with photographic or digitized traces provided to the UNMHSC and UNMH site contact. Single mode fiber must be warranted to operate successfully at 10 Gb/sec and OC-768 / 40 Gb/sec rates regardless of testing results.

### 3.3.5. Edge Hardware (Layer 3 switches) Requirements

3.3.5.1. Layer 3 switches are required for most sites as specified in the detailed site listing, Appendix B.

3.3.5.2. Layer 3 switched must be compatible with existing network hardware in the UNMHSC and UNMH network on a functional, configuration, and physical level, and with existing network management software.

3.3.5.3. General configuration information for the router type is specified in Appendix B: Detailed Site Specifications. These configurations are based on Cisco products, but Cisco-brand hardware is not required. Proposals offering alternate brands and configurations are acceptable, with due consideration of the requirements for compatibility and interoperability. Compatibility with current HSC Network management applications and routing protocols is critical. In particular, all network electronics needs to be able to be managed by CiscoWorks Resource Manager Essentials version 4.3.x via SNMP v3 & SSH and all layer 3 switches need to support OSPF.

### 3.4. Dedicated Fiber Connection from the Women’s Faculty and Midwife Clinic to the Physical Therapy Rehabilitation Clinic

3.4.1. This project component serves to connect the Women’s Faculty and Midwife Clinic facilities at 801 Encino PI NE Suite E-1, Albuquerque, New Mexico to the campus fiber network. The scope includes securing rights to install a UNM-owned underground conduit system with appropriate underground structures such as manholes and pullboxes from the existing system at 1025 Medical Arts Avenue NE (Physical Therapy Rehabilitation Clinic), across Medical Arts Avenue and into 801 Encino. Fiber optic cabling and conduits must meet requirements of Appendix C.



3.4.2. Connectivity Requirements: Bidders shall provide proposals for 24 strand single mode and 48 strand single mode connections with all strands terminated and tested to a bidder provided, approved FDU, as per guidelines in Appendix C, with appropriate manholes, conduit and pullboxes. Options that would provide additional capacity to support future clinics in the Encio Office park (such as additional conduits or larger underground structures) may be included in the bid, but these must be clearly marked as such.

3.4.3. Edge Hardware Requirements: Bidders shall provide at the 1025 Medical Arts fiber end the following termination electronics; Cisco (or equivalent) Two WS-3560E-12D-E with two 10Gigabit X2 LR each. Cisco-brand hardware is not required. Proposals offering alternate brands and configurations are acceptable, with due consideration of the requirements for compatibility and interoperability set forth above and in Section 2.0.

### 3.5. Fiber Connections from the UNM Children's Psychiatric Hospital (CPC) to the Health Sciences and Services Building Zone-hub (HSSBZH)

3.5.1. This project component serves to connect the existing CPC buildings at 1001 Yale Blvd NE, Albuquerque, New Mexico to the existing campus fiber presence at the HSSB facility at 2500 Marble NE in Albuquerque and install single-mode fiber between the main TRs in CPC. The scope includes securing rights to install a UNM-owned underground conduit system with appropriate underground structures such as manholes and pullboxes between those locations and installing fiber optic cabling and copper cabling to specifications given in Appendix C.

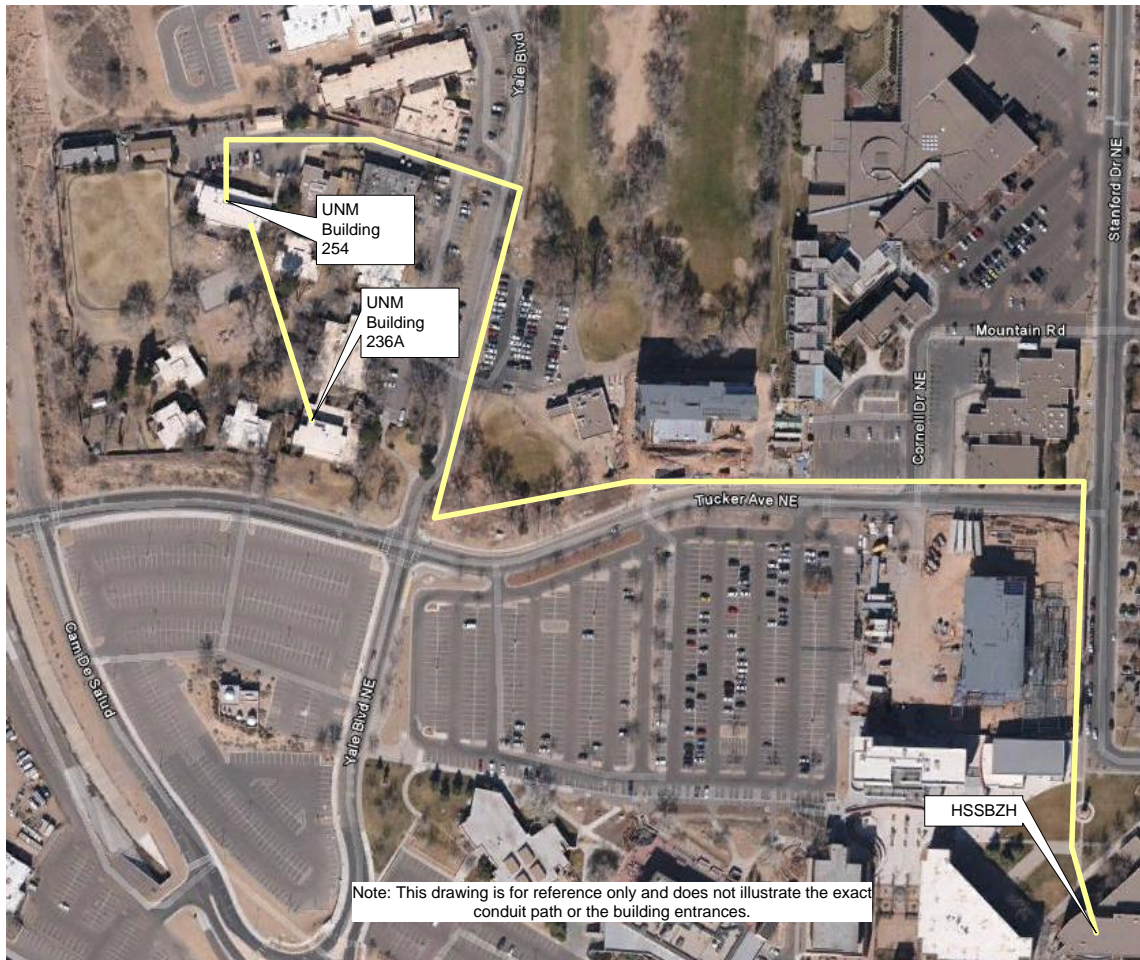

3.5.2. Connectivity Requirements: Bidders shall provide proposals for 24 strand single mode and 48 strand single mode connections with all strands terminated and tested to a bidder provided, approved FDU, as per guidelines in Appendix C, with appropriate manholes, conduit and pullboxes. This path should have maximum practical separation from existing CPC fiber and be terminated in the 2<sup>nd</sup> floor TR of UNM Building 254, New Mexico Children's Psychiatric Center Day Treatment Center, AKA Partial Hospital building.

3.5.3 Bidders shall also provide proposals for 24 strand single mode and 48 strand single mode connections with all strands terminated and tested to a bidder provided, approved FDU, as per guidelines in Appendix C, to connect the 2<sup>nd</sup> floor TR of UNM Building 254, New Mexico Children's Psychiatric Center Day Treatment Center, AKA Partial Hospital building to the first floor TR of UNM building 236A, New Mexico Children's Psychiatric Center Administration Building. IT is suggested by UNM IT Telecomm Facilities Manager that this be planned to run outside the existing buildings due to pathway congestion.

3.5.4. Edge Hardware Requirements: Bidders shall provide the following termination electronics; Cisco (or equivalent) WS-3560E-12D-E with two 10Gigabit X2 LR each. Cisco-brand hardware is not required. These will be deployed in Building 254 and Building 236A. Proposals offering alternate brands and configurations are acceptable, with due consideration of the requirements for compatibility and interoperability set forth above and in Section 2.0.

### 3.6. Fiber Connection from Novitski Hall Zone Hub to the University Psychiatric Hospital (UPC)

3.6.1. This project component serves to connect the existing UPC at 2600 Marble NE, Albuquerque, New Mexico to the existing campus fiber presence at the Novitski Hall Zone Hub located at 2320 Tucker NE, Albuquerque, New Mexico. The scope includes securing rights to install a UNM-owned underground conduit system with appropriate underground structures such as manholes and pullboxes between those locations and installing fiber optic cabling and copper cabling to specifications given in Appendix C.

3.6.2. Connectivity Requirements: Bidders shall provide proposals for 24 strand single mode and 48 strand single mode connections with all strands terminated and tested to a bidder provided, approved FDU, as per guidelines in Appendix C, with appropriate manholes, conduit and pullboxes. Fiber will be terminated in TR 5 at UPC and in the Novitski Hall Zone Hub.

3.6.3. Edge Hardware Requirements: Bidders shall provide at the UPC end the following termination electronics; Cisco (or equivalent) WS-3560E-12D-E with two 10Gigabit X2 LR each. Cisco-brand hardware is not required. Proposals offering alternate brands and configurations are acceptable, with due consideration of the requirements for compatibility and interoperability set forth above and in Section 2.0.



### 3.7. Fiber Connection from UNM Cancer Center (UNMCC) to the Physical Therapy Rehabilitation Clinic

3.7.1. This project component serves to connect the existing UNM Cancer Center Equipment Room at 900 Camino De Salud NE, Albuquerque, New Mexico to the existing campus fiber presence at Physical Therapy Rehabilitation at 1025 Medical Arts Avenue NE, Albuquerque, New Mexico. This project serves to provide a redundant connection to the Medical Arts vicinity that houses the UNM Orthopedics Clinic, Sleep Disorders Clinic, Senior Health Center, Lobo Clinic, Dermatology Clinic, Women's Faculty Clinic and Physical Therapy Rehabilitation Clinic. The scope includes securing rights to install a UNM-owned underground conduit system with appropriate underground structures such as manholes and pullboxes between those locations and installing fiber optic cabling and copper cabling to specifications given in Appendix C. Note that this component is included in component 3.8 and no more than one of either 3.7 or 3.8 will be funded.

3.7.2 This connection must be run diverse to the existing Novitsky to UNM Cancer Center fiber run and fiber connecting OSIS to 1209 and CTH. This is an area that will have extensive construction so the path used must be coordinated with UNM Real Estate, UNM Campus Planning, UNM ITS, and UNMH Facility Planning to prevent future conflicts. This will be a critical backbone connection for multiple patient care buildings so a design that minimizes the potential for accidental damage during future construction is important

3.7.3. Connectivity Requirements: Bidders shall provide proposals for 144 strand single mode, or 216 strand single mode or 288 strand single mode connections with all strands terminated and tested to a bidder provided, approved FDU, as per guidelines in Appendix C, with appropriate manholes, conduit and pullboxes. This run across Lands West needs to be a hardened duct bank whose actual path is planned in conjunction with UNM and UNMH facilities, real estate and other parties

3.7.4. Edge Hardware Requirements: No edge hardware in required for this project.



**This drawing is for reference only and does not illustrate exact service entrance or conduit path**

### **3.8. Fiber Connection from UNM Cancer Center to the Health Sciences and Services Building Zone-Hub (HSSBZH) via Medical Arts**

3.8.1. This project component serves to provide a redundant, diverse and hardened connection from UNM Cancer Center (UNMCC) Equipment Room at 900 Camino De Salud NE, Albuquerque, New Mexico to Physical Therapy Rehabilitation (Rehab) at 1025 Medical Arts Avenue NE, Albuquerque, New Mexico, then to existing campus fiber presence at the Health Sciences and Services Building (HSSB) at 2500 Marble NE in Albuquerque, New Mexico. The scope includes securing rights to install a UNM-owned underground conduit system with appropriate underground structures such as manholes and pullboxes between those locations and installing fiber optic cabling and copper cabling to specifications given in Appendix C. Where existing UNM-owned underground conduit systems are both available and deemed suitable by UNM IT and UNMH they should be used. Note that this component is included in component 3.7 and no more than one of either 3.7 or 3.8 will be funded.

3.8.2 This is designed to connect the HSSB Core electronics to the UNM Cancer Center via Rehab services in Medical Arts. This will provide services to the UNM Cancer Center, OSIS, the 1209 Family Practice building, Carrie Tingly Hospital, and the Medical Arts complex (Telemedicine, Dermatology Clinic, Rehab Service, Sleep Disorders, Orthopedic Clinic, Lobo Clinic).

3.8.2. Connectivity Requirements: Bidders shall provide proposals for 144 strand single mode, or 216 strand single mode or 288 strand single mode connections. All strands must be terminated and tested to a bidder provided, approved FDU, as per guidelines in Appendix C, with appropriate manholes, conduit and pullboxes. This is intended to be run as a single fiber cable, with only 48 strands broken out at Rehab, with the balance running continuously from HSSB to UNMCC. This will provide 48 strands from Rehab to UNMCC and 48 strands from Rehab to HSSB, with the balance running from UNMCC to HSSB. If this is technically unfeasible the location of fusion splice points and how they will be protected needs to identified.

3.8.3 This connection must be run diverse to the existing Novitsky to UNM Cancer Center fiber run and fiber connecting OSIS to 1209 and CTH. This is an area that will have extensive construction so the path used must be coordinated with UNM Real Estate, UNM Campus Planning, UNM ITS, and UNMH Facility Planning to prevent future conflicts. This will be a critical backbone connection for multiple patient care buildings so a design that minimizes the potential for accidental damage during future construction is important.

3.8.4. Core Hardware Requirements: Bidders shall provide at HSSBZH the following termination electronics; one WS-X6716-10G-3C, and eight X2-10GB-LR. Cisco-brand hardware is not required. Proposals offering alternate brands and configurations are acceptable, with due consideration of the requirements for compatibility and interoperability set forth above and in Section 2.0.



### 3.9. Fiber Connection from the Physical Therapy Rehabilitation Clinic to UNM Hospital Operations for Patients and Employees

3.9.1. This project component serves to connect the existing UNM Hospital Operations for Patients and Employees facility located at 933 Bradbury SE, Albuquerque, New Mexico to the existing campus fiber presence located at the Physical Therapy Rehabilitation Clinic at 1025 Medical Arts Avenue NE, Albuquerque, New Mexico. The scope includes securing rights to install a UNM-owned underground conduit system with appropriate underground structures such as manholes and pullboxes between those locations and installing fiber optic cabling and copper cabling to specifications given in Appendix C. We believe there is state owned (NM DOT) conduit system running along I25. We do not have any current agreement to utilize this, but use of the DOT system for portions of this fiber connection would be acceptable if the bidder can secure rights acceptable to UNMH and UNMHSC.

3.9.2. Connectivity Requirements: Bidders shall provide proposals for 24 strand single mode, 48 strand single mode, 72 strand single mode, 96 strand single mode, 144 strand single mode, and 288 strand single mode connections with 24 strands terminated and tested to a bidder provided, approved FDU, as per guidelines in Appendix C, with appropriate manholes, conduit and pullboxes.

3.9.3 Edge Hardware Requirements: Bidders shall provide at HOPE two Cisco WS-X6724-SFP.



Note: This drawing is for reference only and does not illustrate exact conduit path or building entrance

### 3.10. Fiber Connection from the Sleep Disorders Center to the Physical Therapy Rehabilitation Clinic

3.10.1. This project component serves to replace the damaged and unrepairable connection from the Sleep Disorders Center facilities at 1101 Medical Arts Avenue NE, Building 2, Albuquerque, New Mexico to the existing campus fiber network. The scope includes securing rights to install a UNM-owned underground conduit system with appropriate underground structures such as manholes and pullboxes from the existing system at 1025 Medical Arts Avenue NE (Physical Therapy Rehabilitation Clinic), across the parking lots and into the Sleep Disorders Clinic. Fiber optic cabling and conduits must meet requirements of Appendix C.

3.10.2. Connectivity Requirements: Bidders shall provide proposals for 24 strand single mode and 48 strand single mode connections with all strands terminated and tested to a bidder provided, approved FDU, as per guidelines in Appendix C, with appropriate manholes, conduit and pullboxes.

3.10.3 Edge Hardware Requirements: There is no hardware required for this project component.



Note: This drawing is for reference only and does not illustrate exact conduit path or building entrance

### 3.11. Fiber Connection from UNM Hospital to Health Sciences and Services Building Zone-Hub (HSSBZH)

3.12.1 This project component serves to upgrade the connectivity of UNM Hospital, located at 2211 Lomas Blvd NW Albuquerque, New Mexico, to the HSC core switch in HSSB located at 2500 Marble NE in Albuquerque, New Mexico and improve network performance by upgrading critical components to faster connectivity. The scope includes securing rights to install a UNM-owned underground conduit system with appropriate underground structures such as manholes and pullboxes from the existing UNMH Data Center located beneath UNMH Main to HSSBZH and installing fiber optic cabling and copper cabling to specifications given in Appendix C.

3.12.2 Connectivity Requirements: Bidders shall provide proposals for 72 strand single mode, 96 strand single mode, or 144 strand single mode, or 216 strand single mode connections with all strands terminated and tested to a bidder provided, approved FDU, as per guidelines in Appendix C, with appropriate manholes, conduit and pullboxes. Where practical this should be run diverse to the existing fiber optic connection from BBRP.

3.12.3 Edge Hardware Requirements: Bidders shall provide at the UNMH Data Center end the following termination electronics; Cisco (or equivalent) two WS-X6716-10G-3C and sixteen X2-10GB-LR.

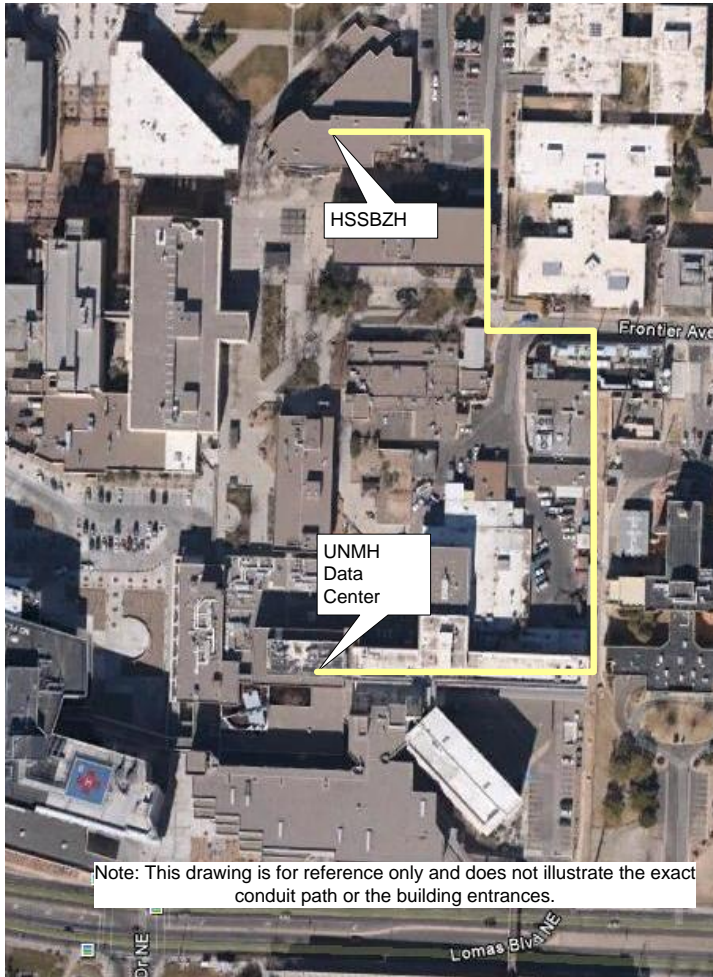

### **3.12. Upgrade for Internet Edge in HSSB Zone Hub and Novitski Zone Hub**

3.13.1. This project component serves to start the process of upgrading the HSC Internet Edge to support the full Internet BGP routing table, 10 gigabit connectivity and multi-gigabit data rates. Currently this is a pair of Cisco 6509Es (one in each of two buildings) each with one Supervisor 32-10G, one FWSM and two ws-x6516s. It appears the most cost effective upgrade path is to replace the supervisors with more capable ones that can support both larger route tables and more modern security blades.

3.13.2 Hardware Requirements: Bidders shall provide the following electronics; Two Cisco Catalyst 6500 Series Virtual Switching Supervisor Engine 720 with two 10 Gigabit Ethernet ports and MSFC3 PFC3C XL (VS-S720-10G-3CXL).

### **3.13. Upgrade for Network Security in HSSB Zone Hub and Novitski Zone Hub**

3.13.1. This project component serves to upgrade the HSC Internet Edge network security system to support multi-gigabit speeds. It would be desirable to allow this at 5 Gb/sec or faster rates, but approaches that support 3 gigabit per second or higher sustained flow would still be interesting. All systems must natively support IPv6 and accept both 10gig Ethernet connections, (preferably via industry standard 10 Gb modules) and gigabit connections.

3.13.2 Our current system consists of several different elements.

3.13.2.a A network tap on the output from the network firewall that allows redirection to multiple destinations at gig or 10 gigabit speed. We currently use NetOptics for the tap.

3.13.2.b An IDS system. This is addressed in project component 3.14 and is not within the scope of 3.13

3.13.2.d An inline security appliance that provides a very low false positive rate for attacks and allows selectively dropping inside and outside source/destinations by specific IP address and selectively blocking protocols such as peer-to-peer. We currently use a Tipping Point, but are open to other vendors. Device must be most commonly deployed by end-users in automatic IPS mode.

3.13.3 Network Security Hardware requirements. Bidders shall provide the equipment as listed

3.13.3.a. Two 10 gigabit in-line automatic optical bypass switches providing generally the same capability as the NetOptics 10 gigabit iBypass IBPO-HBLR-XFP. These must be suitable to use with the in-line security appliance (3.13.3.c).

3.13.3.b Two 10Gb multi-port taps with capability to each support at least four 10 gigabit SPAN ports to at least 4 10 gigabit monitoring ports, as well as at least four 1 gigabit SPAN ports and at least six 1 gigabit monitoring ports. In general we would like a similar feature set as the NetOptics Director xStream or xStream Pro, but cost competitive options would be interesting.

3.13.3.c Two multi-gigabit in-line security appliances supporting examination of IPv4, IPv6 and IPv6 tunneling, with input and output via a 10Gb fiber interface (additional gigabit connections are fine). We are thinking that the capabilities of the TippingPoint/HP 5100N/6100N series are well suited to our needs, so COTS solutions that are generally similar would be interesting. The 10Gb interfaces must be compatible with the bypass switches (3.13.3.a).

### **3.14 Upgraded HSC Intrusion Detection System**

3.14.1 This project component is to upgrade the hardware of the HSC IDS with new servers. Increases in network utilization and aging equipment have made the limitations of the existing hardware clear. This replaces the primary sensors and the database server with new hardware.

3.14.2 IDS Hardware Requirements: Bidders shall provide the following electronics;  
Three rack mount servers, each with 2 or more Xeon X5670 or more powerful processors, 16GB or more RAM, 10 15K RPM SA SCSI drives of 600GB or larger capacity, high performance RAID controller for SA SCSI drives, Intel gigabit server NIC xyz and redundant AC power supply. In addition we require a total of two dual port 10GB high performance NICs, comparable to the Naptech NT20E2 or Endace DAG 9.2X2.

## Appendix A: Site Connectivity Drawings

The following drawings provide a graphical depiction of the connectivity solicited by this RFP. The drawings are schematic in nature and are intended to provide an overview only. In the event of a discrepancy between the drawings and the Detail Site Specifications or any written description or specification in this RFP, the written version shall be considered to be authoritative.

Full size drawings may be obtained by a request made to Melissa Crews at [MCrews@salud.unm.edu](mailto:MCrews@salud.unm.edu)

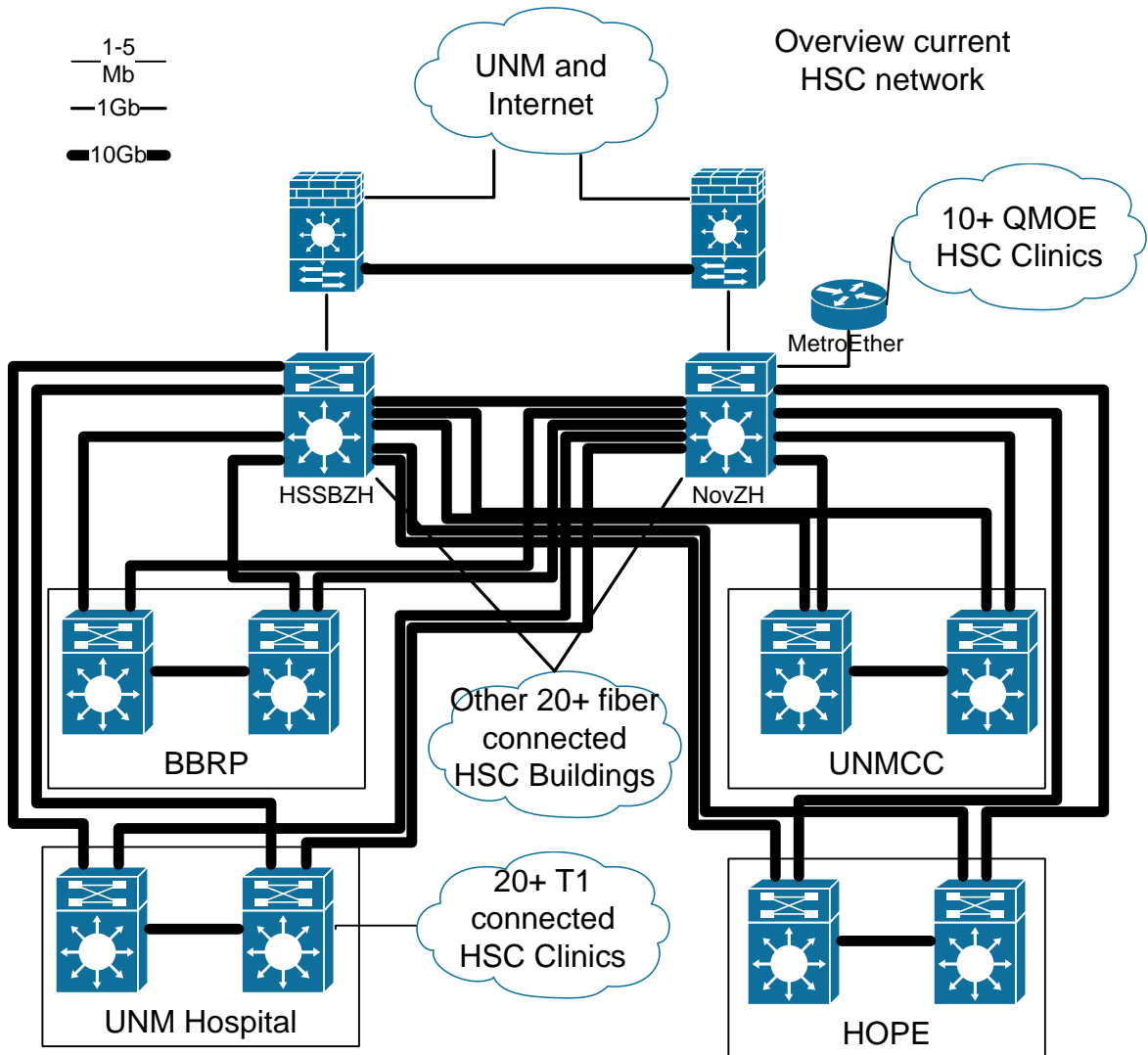

## Appendix B: Detailed Site Specifications

The following pages provide information for each site in the vicinity of Albuquerque, New Mexico, for which bids are solicited.

**Site #1: Novitski Hall zone-hub (2320 Tucker NE), pp. 16,22-30**

Novitski Hall zone-hub (novzh) is one of the two core network hubs in the HSC network. It contains much of the core electronics for the HSC, a Qwest POP, and much of the fiber that interconnects HSC buildings, and has fiber connections to the UNM network.

**Site #2: UNMHSC Health Sciences and Services Building Zone-hub (2500 Marble NE), pp. 16, 19, 23-30**

The HSSB zone hub (hssbzh) is one of the two core network hubs in the HSC network. It contains much of the core electronics for the HSC, and is the only fiber connection for over half of the HSC buildings. It also has fiber connections to the UNM network.

**Site #3: UNMH Hospital (2211 Lomas Blvd. NE), pp. 24**

This connects to the UNMH main complex. This is a major portion of UNM Hospital and is essential for providing patient care in the medical center. It contains the main operating room complex, radiology, and multiple outpatient clinics and inpatient floors.

**Site #4: UNMHSC UNM Cancer Center Zone-hub (1201 Camino de Salud NE), pp. 18-20**

This is located in the new UNM Cancer Center. This contains the fiber that connects UNMCC to the rest of the HSC and is the secondary path to OSIS (Site #19).

**Site #5: UNMH Women's Faculty and Midwife Clinic (801 Encino Pl. NE, Suite E-1), pp. 15**

The clinic provides gynecological and obstetrical care, preconception counseling, treating both minor and major gynecological issues.

**Site #6: UNMH Physical Therapy Rehabilitation Clinic (1025 Medical Arts Ave. NE), pp. 15, 18-19, 21, 23**

This clinic provides outpatient physical therapy services.

**Site #7: UNMH Children's Psychiatric Hospital (1001 Yale NE), pp. 16**

UNM Children's Psychiatric Center provides intensive psychiatric treatment to children and adolescents through the age of 17. Acute inpatient care, residential care and partial (day) hospital care are provided in various settings on the Center's campus.

**Site #8: UNM Psychiatric Hospital (2600 Marble NE), pp. 17**

The UNM Psychiatric Center offers a wide spectrum of innovative in- and outpatient services, from addiction and substance abuse programs to senior care to psychiatric emergency services. It is the largest community mental health provider in the state of New Mexico with telehealth/telemedicine links throughout communities, schools, corrections facilities and more.

**Site #9: UNM Hospital Operations for Patients and Employees (933 Bradbury SE), pp. 21**

HOPE contains the UNMH HR, IT, Finance departments and also contains the offices for the UNM Medical Group. It also contains a Maternity & Family Planning Clinic.

**Site #10: Sleep Disorders Center (1101 Medical Arts Avenue NE), pp. 23**

Sleep Disorders Center contains the outpatient sleep clinic.

Each specification sheet provides site physical and contact information, as well as connectivity and hardware requirements.

**Connectivity:** Specified in terms of the number of single mode optical fibers desired. Please see section 3.3.4 and appendix C for requirements.

**Hardware:** Specified in terms of the Cisco Systems type/model desired for the primary layer 3 switch(es) to provide OSI Layer 3 'edge' connectivity for the circuits. Other brands or systems may be proposed, but bidders are cautioned that the compatibility requirements of Section 3.0 herein must be met.

**Facility #1:** **Novitski Hall Zone-hub**  
 2320 Tucker NE  
 Albuquerque, NM 87106  
 505-272-xxxx

**Contact:** Matt Braun  
 505-272-3270

**Funding year:** FY3-2009

**Connectivity:** See RFP Section 3.3 (pp. 11-13) for general UNM routing and connectivity requirements.

- 24 strand single mode or 48 strand single mode connections to the University Psychiatric Hospital per RFP Section 3.6 (p. 17) and described in Appendix A: Site Connectivity, p27

**Hardware:**

RFP Section 3.12 Internet Edge Upgrade

Product	Description	Quantity
VS-S720-10G-3CXL	Cisco Catalyst 6500 Series Virtual Switching Supervisor Engine 720 with two 10 Gigabit Ethernet ports and MSFC3 PFC3C XL	1

RFP Section 3.13 Internet Edge Security Upgrade

Product	Description	Quantity
HP JC022A or JC577A	HP N series 5 or 8 GB/sec IPS	1
10GBASE-LR XFP	10GBASE-LR XFP Module compatible with IPS	2
IBPO-HBLR-XFP	NetOptics iBypass IBPO-HBLR-XFP	1
DIR-2400XP	NetOptics Director xStream Pro	1
SFP+KT-LR	Fiber LR SFP+ Transceiver with cable	2

RFP Section 3.14 Upgrade HSC Intrusion Detection System

Product	Description	Quantity
Server	Rack mount server, 2+ Xeon X5670 or more powerful processor, 16 or more GB of RAM, Ten 15K RPM SA SCSI drive of 600GB or larger, high performance RAID controller, two or more Intel server 1000/PRO ports, dual AP power supply.	2
High performance dual port 10GB adaptor	Similar to Naptech NT20E2 or Endace DAG 9.2X2	1

**Facility #2: UNMHSC Health Sciences and Services Building Zone-Hub**  
 2500 Marble NE  
 Albuquerque, NM 87106  
 505-272-5849

**Contact:** Matt Braun  
 505-272-3270

**Funding year:** FY3-2009

**Connectivity:** See RFP Section 3.3 (pp. 11-13) for general UNM routing and connectivity requirements.

- 24 strand single mode or 48 strand single mode connections to the UNM Children's Psychiatric Hospital per RFP Section 3.5 (p. 15) and described in Appendix A: Site Connectivity, p. 27.
- 144 strand single mode, 216 strand single mode or 288 strand single mode connections to the UNM Cancer Center per RFP Section 3.8 (p. 19) and described in Appendix A: Site Connectivity, p. 27.
- 144 strand single mode, 216 strand single mode or 288 strand single mode connections to UNM Hospital per RFP Section 3.11 (p.24) and described in Appendix A: Site Connectivity, p. 27.

**Hardware:**

RFP Section 3.8 Fiber Connection from UNM Cancer Center to the Health Sciences and Services Building Zone-Hub (HSSBZH) via Medical Arts

Product	Description	Quantity
WS-X6716-10G-3C=	Catalyst 6500 16 port 10 Gigabit Ethernet w/ DFC3C (req X2)	1
X2-10GB-LR	10GBASE-LR X2 Module	8

RFP Section 3.12 Internet Edge Upgrade

Product	Description	Quantity
VS-S720-10G-3CXL	Cisco Catalyst 6500 Series Virtual Switching Supervisor Engine 720 with two 10 Gigabit Ethernet ports and MSFC3 PFC3C XL	1

RFP Section 3.13 Internet Edge Security Upgrade

Product	Description	Quantity
HP JC022A or JC577A	HP N series 5 or 8 GB/sec IPS	1
10GBASE-LR XFP	10GBASE-LR XFP Module compatible with IPS	2
IBPO-HBLR-XFP	NetOptics iBypass IBPO-HBLR-XFP	1
DIR-2400XP	NetOptics Director xStream Pro	1
SFP+KT-LR	Fiber LR SFP+ Transceiver with cable	2

RFP Section 3.14 Upgrade HSC Intrusion Detection System

Product	Description	Quantity
Server	Rack mount server, 2+ Xeon X5670 or more powerful processor, 16 or more GB of RAM, Ten 15K RPM SA SCSI drive of 600GB or larger, high performance RAID controller, two or more Intel server 1000/PRO ports, dual AP power supply.	1
High performance dual port 10GB adaptor	Similar to Naptech NT20E2 or Endace DAG 9.2X2	1

**Facility #3:** **UNM Hospital**  
2211 Lomas Blvd. NE  
Albuquerque, NM 87106  
505-272-2111

**Contact:** Matt Braun  
505-272-3270

**Funding year:** FY3-2009

**Connectivity:** See RFP Section 3.3 (pp. 11-13) for general UNM routing and connectivity requirements.

- 144 strand single mode, or 216 strand single mode or 288 strand single mode connections to HSSBZH Hub per RFP Section 3.11 (p.24) and described in Appendix A: Site Connectivity, p. 22.

**Hardware:**

RFP Section 3.11 Fiber Connection from UNM Hospital to Health Sciences and Services Building Zone-Hub

Product	Description	Quantity
WS-X6716-10G-3C=	Catalyst 6500 16 port 10 Gigabit Ethernet w/ DFC3C (req X2)	2
X2-10GB-LR	10GBASE-LR X2 Module	16

**Facility #4:** **UNM Cancer Center Zone-Hub**  
1201 Camino de Salud NE  
Albuquerque, NM 87106  
505-272-4946

**Contact:** Matt Braun  
505-272-3270

**Funding year:** FY3-2009

**Connectivity:** See RFP Section 3.3 (pp. 11-13) for general UNM routing and connectivity requirements.

- 144 strand single mode, or 216 strand single mode or 288 strand single mode fiber to Physical Therapy Rehabilitation Services per RFP section 3.7. Note that 3.7 and 3.8 are exclusive, only at most one will be funded.
- 144 strand single mode, or 216 strand single mode or 288 strand single mode to HSSBZH and Physical Therapy Rehabilitation Services per RFP section 3.8. Note that 3.7 and 3.8 are exclusive, only at most one will be funded.

**Hardware:** There are no hardware requirements for this facility.

**Facility #5:** **UNMH Women's Faculty and Midwife Clinic**  
801 Encino Pl. NE, Suite E-1  
Albuquerque, NM 87102  
505-925-4940

**Contact:** Matt Braun  
505-272-3270

**Funding year:** FY3-2009

**Connectivity:** See RFP Section 3.3 (pp. 11-13) for general UNM routing and connectivity requirements.

- 24 strand single mode or 48 strand single mode connections to the Physical Therapy Rehabilitation Clinic per RFP Section 3.4 (p. 13) and described in Appendix A: Site Connectivity, p. 27

**Hardware:** None required – All hardware used here will be layer 2 access electronics.

**Facility #6: UNMH Physical Therapy Rehabilitation Clinic**  
 1025 Medical Arts Avenue NE  
 Albuquerque, NM 87102  
 505-272-9020

**Contact:** Matt Braun  
 505-272-3270

**Funding year:** FY3-2009

This site is included in four different project components.

1. To the Women’s Faculty and Midwife Clinic. Connectivity (See RFP Section 3.3 (pp. 11-13) for general UNM routing and connectivity requirements.) 24 strand single mode or 48 strand single mode connections to the Women’s Faculty and Midwife Clinic per RFP Section 3.7 (p. 13) and described in Appendix A: Site Connectivity, p. 22. Hardware: Cisco WS-3560E-12D-E, or Equivalent and 10 Gigabit X2 LR (2)
2. To the UNM Cancer Center. Connectivity (See RFP Section 3.3 (pp. 11-13) for general UNM routing and connectivity requirements.) 72 strand single mode, or 96 strand single mode, or 144 strand single mode, or 216 strand single mode or 288 strand single mode connections to the Outpatient Surgery and Imaging Service per RFP Section 3.10 (p. 18) and described in Appendix A: Site Connectivity, p. 22.
3. To. Fiber Connection from UNM Cancer Center to the Health Sciences and Services Building 1st Floor Network Room (HSSB) via Medical Arts. Connectivity See RFP Section 3.11 (
4. To the UNM Hospital Operations for Patients and Employees Facility. Connectivity (See RFP Section 3.3 (pp. 11-13) for general UNM routing and connectivity requirements.) 24 strand single mode or 48 strand single mode connections to the UNM Hospital Operations for Patients and Employees facility per RFP Section 3.12 (p. 20) and described in Appendix A: Site Connectivity, p. 22.

**Hardware:**

3560E distribution switch

Product	Description	Quantity
WS-C3560E-12D-E	Catalyst 3560E 12 Ten GE (X2) ports, IPS software	2
S356EVK9T-12255SE	CAT 3560E IOS UNIVERSAL WITH WEB BASED DEV MGR	2
C3K-PWR-300WAC	Catalyst 3560E-12D and 3560E-12SD 300WAC power supply	4
CAB-C13-C14-AC	Power cord, C13 to C14 (recessed receptacle), 10A	4
C3K-FAN-16CFM	Fan Module for the Catalyst 3560E-12D	8
X2-10GB-LR	10GBASE-LR X2 Module	4
GLC-LH-SM=	Gigabit Ethernet SFP, LC connector, LX/LH transceiver	4
GLC-SX-MM=	Gigabit Ethernet SFP, LC connector, SX transceiver	10
GLC-T=	1000BASE-T SFP	4
CVR-X2-SFP	TwinGig Converter Module	16

**Facility #7: UNMH Children's Psychiatric Hospital**

1001 Yale Blvd. NE  
Albuquerque, NM 87106  
505-272-2890

**Contact:** Matt Braun  
505-272-3270

**Funding year:** FY3-2009

**Connectivity:** See RFP Section 3.3 (pp. 11-13) for general UNM routing and connectivity requirements.

- 24 strand single mode or 48 strand single mode connections to the Health Sciences and Services Building Zone-hub per RFP Section 3.8 (p. 16) and described in Appendix A: Site Connectivity, p. 22.

**Hardware:**

RFP Section 3.5 Fiber Connections from the UNM Children's Psychiatric Hospital (CPC) to the Health Sciences and Services Building Zone-hub

**3560E distribution switch**

Product	Description	Quantity
WS-C3560E-12D-E	Catalyst 3560E 12 Ten GE (X2) ports, IPS software	2
S356EVK9T-12255SE	CAT 3560E IOS UNIVERSAL WITH WEB BASED DEV MGR	2
C3K-PWR-300WAC	Catalyst 3560E-12D and 3560E-12SD 300WAC power supply	4
CAB-C13-C14-AC	Power cord, C13 to C14 (recessed receptacle), 10A	4
C3K-FAN-16CFM	Fan Module for the Catalyst 3560E-12D	8
X2-10GB-LR	10GBASE-LR X2 Module	4
GLC-LH-SM=	Gigabit Ethernet SFP, LC connector, LX/LH transceiver	4
GLC-SX-MM=	Gigabit Ethernet SFP, LC connector, SX transceiver	10
GLC-T=	1000BASE-T SFP	4
CVR-X2-SFP	TwinGig Converter Module	16

**Facility #8: UNM Psychiatric Hospital**  
2600 Marble NE  
Albuquerque, NM 87106  
505-272-2800

**Contact:** Matt Braun  
505-272-3270

**Funding year:** FY3-2009

**Connectivity:** See RFP Section 3.3 (pp. 11-13) for general UNM routing and connectivity requirements.

- 24 strand single mode or 48 strand single mode fiber to Novitski Hall per RFP Section 3.6 (p. 17) and described in Appendix A: Site Connectivity, p. 22.

**Hardware:**

3560E distribution switch

Product	Description	Quantity
WS-C3560E-12D-E	Catalyst 3560E 12 Ten GE (X2) ports, IPS software	2
S356EVK9T-12255SE	CAT 3560E IOS UNIVERSAL WITH WEB BASED DEV MGR	2
C3K-PWR-300WAC	Catalyst 3560E-12D and 3560E-12SD 300WAC power supply	4
CAB-C13-C14-AC	Power cord, C13 to C14 (recessed receptacle), 10A	4
C3K-FAN-16CFM	Fan Module for the Catalyst 3560E-12D	8
X2-10GB-LR	10GBASE-LR X2 Module	4
GLC-LH-SM=	Gigabit Ethernet SFP, LC connector, LX/LH transceiver	4
GLC-SX-MM=	Gigabit Ethernet SFP, LC connector, SX transceiver	10
GLC-T=	1000BASE-T SFP	4
CVR-X2-SFP	TwinGig Converter Module	16

**Facility #9:** **UNM Hospital Operations for Patients and Employees Facility**  
933 Bradbury SE  
Albuquerque, NM 87102  
505-272-6700

**Contact:** Matt Braun  
505-272-3270

**Funding year:** FY3-2009

**Connectivity:** See RFP Section 3.3 (pp. 11-13) for general UNM routing and connectivity requirements.

- 24 strand single mode, 48 strand single mode, 72 strand single mode, 96 strand single mode, 144 strand single mode, 216 strand single mode or 288 strand single mode connections to the Physical Therapy Rehabilitation Clinic per RFP Section 3.12 (p. 20) and described in Appendix A: Site Connectivity, p. 22.

**Hardware:**

RFP section 3.9 Fiber Connection from the Physical Therapy Rehabilitation Clinic to UNM Hospital Operations for Patients and Employees

Distribution electronics for existing 6509s

Product	Description	Quantity
WS-X6724-SFP	24 port High Performance Mixed Media Gigabit Ethernet interface module	2
GLC-LH-SM=	Gigabit Ethernet SFP, LC connector, LX/LH transceiver	8

**Facility #10: Sleep Disorders Center**

1101 Medical Arts Avenue NE  
Albuquerque, NM 87106  
505-272-xxxx

**Contact:** Matt Braun  
505-272-3270

**Funding year:** FY3-2009

**Connectivity:** See RFP Section 3.3 (pp. 11-13) for general UNM routing and connectivity requirements.

24 strand single mode or 48 strand single mode fiber to Physical Therapy Rehabilitation Clinic per RFP section 3.14.

**Hardware:** None required, as the site uses only layer 2 access electronics.

## **Appendix C: UNM IT/ Telecommunications Specifications and Design Guidelines**

UNM IT Telecommunications Specifications and Design Guidelines are located on the UNM IT web server; <http://it.unm.edu/communications/designguidelines/>

Please note this advisory located there:

These design guidelines shall not be used as the final specification or bid document for any specific new or renovation project. This document is the basis in a process of collaboration between the architect/designer, engineer, contractor, the occupant, and the University of New Mexico's Facilities and Real Estate Management and the Information Technologies organization.

Detailed and specific requirements for a project will depend on the programmatic use of the space(s) developed during the project formulation and design phases of the project.

As result of these efforts, a bid-quality document containing commonly accepted and standard industry language shall be provided to the project.

The user of these design guidelines and guide specifications is responsible to read the Foreword and Communications - General sections of these documents and use the documents as prescribed.

Any questions concerning these documents should be addressed to the Information Technologies Facilities and Engineering Manager at (505) 277.0111.